



793C Mining Truck



CAT[®]

Cat[®] 3516B Electronic Unit Injection Engine		
Gross power at 1750 rpm	1715 kW	2300 hp
Flywheel power at 1750 rpm	1615 kW	2166 hp
Body capacity (SAE 2:1)	Customized	Customized
Gross machine operat. weight	384 000 kg	846,000 lb
Payload weight		
Standard configuration	218+ metric tons	240+ tons

793C Mining Truck

Engineered for performance, designed for comfort, built to last.

Mechanical Power Train

- ✓ *Starting with the high torque rise, Caterpillar® 3516B Diesel Engine, through the electronic, six-speed power shift transmission, the mechanical power train is designed and built by Caterpillar, assuring the highest standards for quality, performance, efficiency and reduced operating costs.*
pg. 4-5

Engine Power Train Integration

The Caterpillar intelligent power train combines engine, transmission and brake information over the CAT Data Link to optimize overall truck performance. The CAT Data Link allows the engine and transmission to electronically exchange information so the components work together as a system for increased component life and improved operator comfort. The Electronic Technician (ET) software program can access stored diagnostic data to significantly reduce downtime and improve troubleshooting.
pg. 6-7

Oil-cooled Disc Brakes

Caterpillar four-wheel forced oil-cooled, multiple disc brakes are continuously cooled for exceptional, non-fade braking and retarding. The Integrated Braking Control (IBC) system integrates the Automatic Retarder Control (ARC) on all wheels and Traction Control System (TCS) on the drive wheels into one system to enhance truck performance and productivity, and improve operator confidence. **pg. 8**

Total performance.

The 793C is designed for high production, assuring lowest cost-per-ton hauling in mining applications.

Reliable, durable operation.

Rugged construction and easy maintenance guarantee extended life with low operating costs.



Structures

Caterpillar truck frames are built to resist the most severe, twisting high impact applications. Mild steel provides flexibility, durability, and resistance to impact loads. The frame incorporates 22 castings and two forgings in high stress areas for increased strength and extended life. **pg. 10**

Operator's Station

The 793C operator's station has been significantly improved over previous models by ergonomically designing for total machine control in a comfortable and productive environment. All controls, levers, switches and gauges are positioned to maximize productivity and minimize operator fatigue. Electronic hoist control provides ease of operation. The integral ROPS structure provides superior operator protection. **pg. 12**

Vital Information Management System (VIMS)

VIMS monitors vital machine systems and functions. It helps coach the operator in the operation of the machine and alerts him to out of specification conditions. Down time is reduced by allowing service personnel to access machine data for faster, more accurate diagnosis. VIMS provides information to enhance equipment management, increase productivity and reduce cost-per-ton. **pg. 13-14**



✓ *New feature*

Engine

Both the 3516B engine and 3516B High Displacement engine deliver the power and reliability necessary to perform in the world's most demanding mining applications.

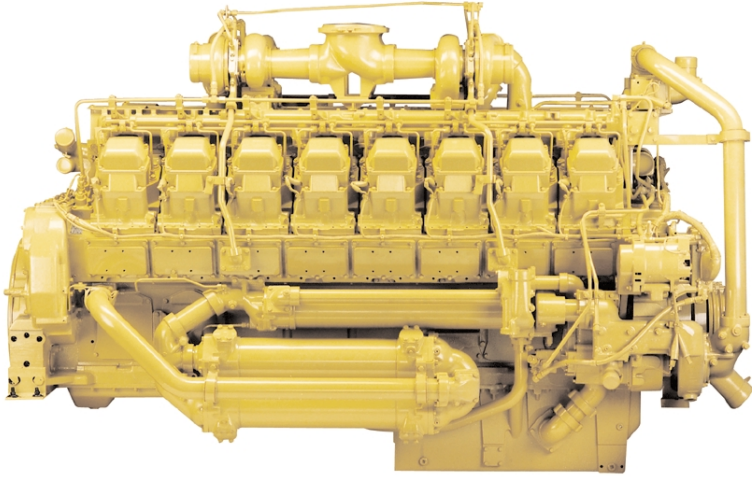

① **3516B High Displacement Diesel Engine**

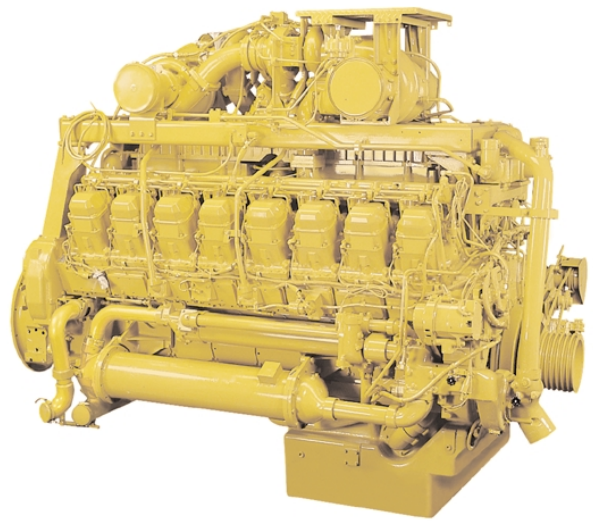

② **3516B Engine**

1 The Caterpillar 3516B High Displacement Diesel Engine

with a longer piston stroke, new crankshaft, rods, pistons, and single stage turbochargers, is available for optimum performance in most applications. This new high displacement engine is designed for extended hours of service between scheduled overhauls, reduced operating costs, and optimum efficiency.

- Compliant with U.S. Environmental Protection Agency Tier 1 emissions standards, this engine is designed for maximum operating efficiencies at altitudes under 2750 m (9,000 ft).

2 The Caterpillar 3516B Engine

(not available in North America) remains the natural choice for most high altitude applications above 2750 m (9,000 ft). It is designed for extended hours of service between scheduled overhauls and reduced operating costs.

Both 3516B engines provide unmatched combustion efficiency:

- **Electronic Unit Injector (EUI)** is a proven high-pressure, direct injection fuel system. New components of the fuel system provide 22 percent higher injection pressures than the previous generation of 3500 engines. The higher pressures provide improved response time and more efficient fuel burn with lower emissions and less smoke.
- **Electronic Control Module (ECM)** utilizes advanced engine management software to monitor, control and protect the engine utilizing self-diagnosing electronic sensors. The module controls a wide spectrum of engine functions, providing infinitely variable injection timing to maintain peak performance.
- **Separate circuit aftercooler** allows the aftercooler coolant to operate at lower temperatures than jacket water for a denser air charge in the combustion chamber.
- **The 23 percent torque rise** provides high lugging force during acceleration and less down shifting on grade or in soft underfooting for faster cycle times. Torque rise effectively matches the transmission shift points to maximize efficiency and yield higher performance.
- 500 hour service interval for engine oil, oil and fuel filter changes, increasing mechanical availability and production.
- Engine replacement and installation times reduced by more than 40 percent compared to previous models through redesign of engine and hydraulic systems.
- Additional electronic protection of the engine during cold starts, high altitude operations, air filter plugging and high exhaust temperature conditions.
- Quick diagnosis of engine conditions enable effective maintenance and repairs utilizing the Electronic Technician (ET) service tool.

Mechanical Power Train

Completely designed and manufactured by Caterpillar to assure maximum efficiency, high quality, extended service life and low operating costs.

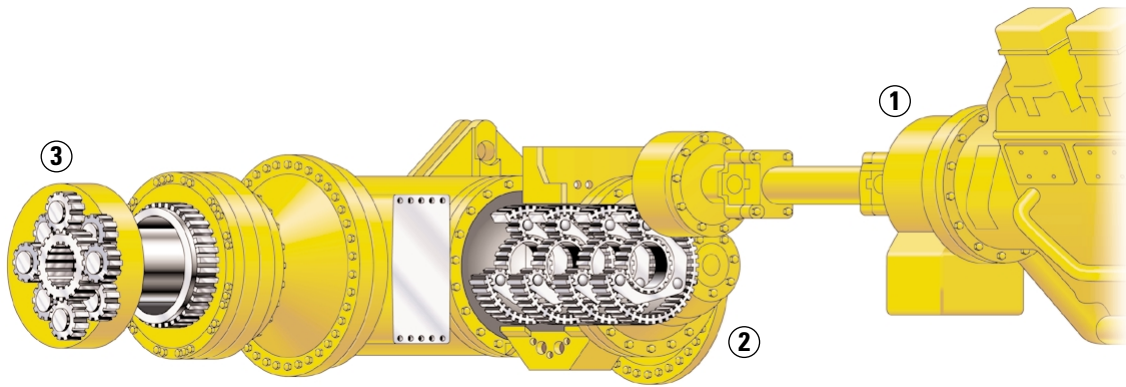

The Cat mechanical power train is designed for optimum component match. A wide application range is available in each gear. A 35 percent step between each gear allows the transmission to utilize the full torque range of the 3516B engine, resulting in fewer shifts for extended power train life.

- Overall power train efficiency of between 82 and 85 percent is maintained up to 15 percent effective grade.
- Electric drive power train trucks produce their peak efficiency of 76 to 79 percent at approximately five to seven percent effective grade.
- Higher power train efficiency provides faster truck speeds with less fuel consumption.

Transmission/Chassis Control (TCC) module communicates over the Cat Data Link with the engine ECM to manage engine speed during shifts for increased clutch life and operator comfort. When the transmission is in sixth gear, the engine is allowed to run out to 2000 rpm, so the truck can achieve speeds up to 55 km/h (34 mph). The shifts points are set at the factory for optimal performance, efficiency and component life.

- **TCC monitors and records key operating conditions** and parameters for later downloading and diagnostic troubleshooting by service personnel.

1 Lock-up Torque Converter combines the maximum rimpull and cushioned shifting of torque converter drive with the efficiency and performance of direct drive. The lock-up clutch engages at approximately 7.2 km/h (4.5 mph). During shifts the lock-up clutch quickly releases and re-engages to reduce power train torque loads. This action provides for smoother shifting, extended component life, and increased operator comfort.

- **Rimpull** at stall is 1005 kN (225,900 lb) – 28 percent gradeability at maximum operating weight.

2 Six-speed, planetary power shift transmission is designed for the high horsepower of the 3516B engine. The design makes the transmission more robust, with an extended life between overhauls. To accomplish this the transmission utilizes:

- Larger and additional clutch discs and plates to transmit the horsepower.
- Increased piston size to lower clutch unit pressure, increasing service life of clutch discs and rotating seals.
- Additional gears in planetary sets to increase gear and bearing life. Spreads loads over more contact area.

- The torque converter and transmission utilize a common oil circuit with fewer hoses and connections to provide a simpler system, with cooler, cleaner oil and extended component life.

3 Large, differential and double-reduction final drives provide torque multiplication of 28.8:1 to further reduce stress on the drive train.

The hydraulic steering system provides precise, controllable steering:

- The steering system is a separate circuit from the other hydraulic circuits to prevent cross contamination and provide easier serviceability.
- Supplemental steering is provided by accumulators for emergency use. Designed to provide at least three 90 degree turns after engine failure.

Cat center mounted rims and cast rear wheels are mounted using studs and nuts to minimize maintenance and provide outstanding durability.

Engine/Power Train Integration

Information from the engine and transmission work together intelligently to maximize production, efficiency and extend service life of the components.

The **CAT Data Link** electronically connects the engine and transmission controls to optimize overall power train performance, reliability and component life for reduced power train operating costs. To lower operating cost-per-ton the system incorporates:

- **Controlled throttle shift.** Engine rpm is regulated during a shift to reduce driveline torque stress for smoother shifts, extended component life and improved operator comfort.
- **Directional shift management** regulates engine speed during directional shifts to prevent damage caused by high speed directional changes. This prevents shifts into reverse when forward ground speeds are in excess of 4.8 km/h (3 mph). This protects the transmission from high shock loads created by abusive directional shifts.
- **Neutral coast inhibitor** prevents the transmission from shifting to neutral at speeds above 6.5 km/h (4 mph). This protects the transmission against operating with insufficient lubrication.
- **Body-up shift inhibitor** prevents the transmission from shifting above the pre-programmed gear without the body fully lowered.
- **Reverse neutralized with body-up.** If the hoist lever is activated and the transmission is in reverse, the transmission will automatically shift to neutral.
- **Engine overspeed protection.** The transmission control senses possible overspeed conditions and upshifts one gear. If overspeed conditions occur in top gear, the lock-up clutch is disengaged.
- **Programmable top gear.** The transmission top gear may be electronically set using ET. This feature helps operators maintain speed limits. Reprogramming of the top gear can only be accomplished with the ET service tool.

- **Anti-hunt function.** The transmission will not allow an upshift or downshift for approximately 2.3 seconds after a shift has occurred. This prevents gear hunting when operating near a shift point and minimizes transmission shifts to increase component life.
- **Downshift inhibitor.** The transmission will not allow a downshift to occur until engine speed reaches the downshift point, preventing an engine overspeed condition.

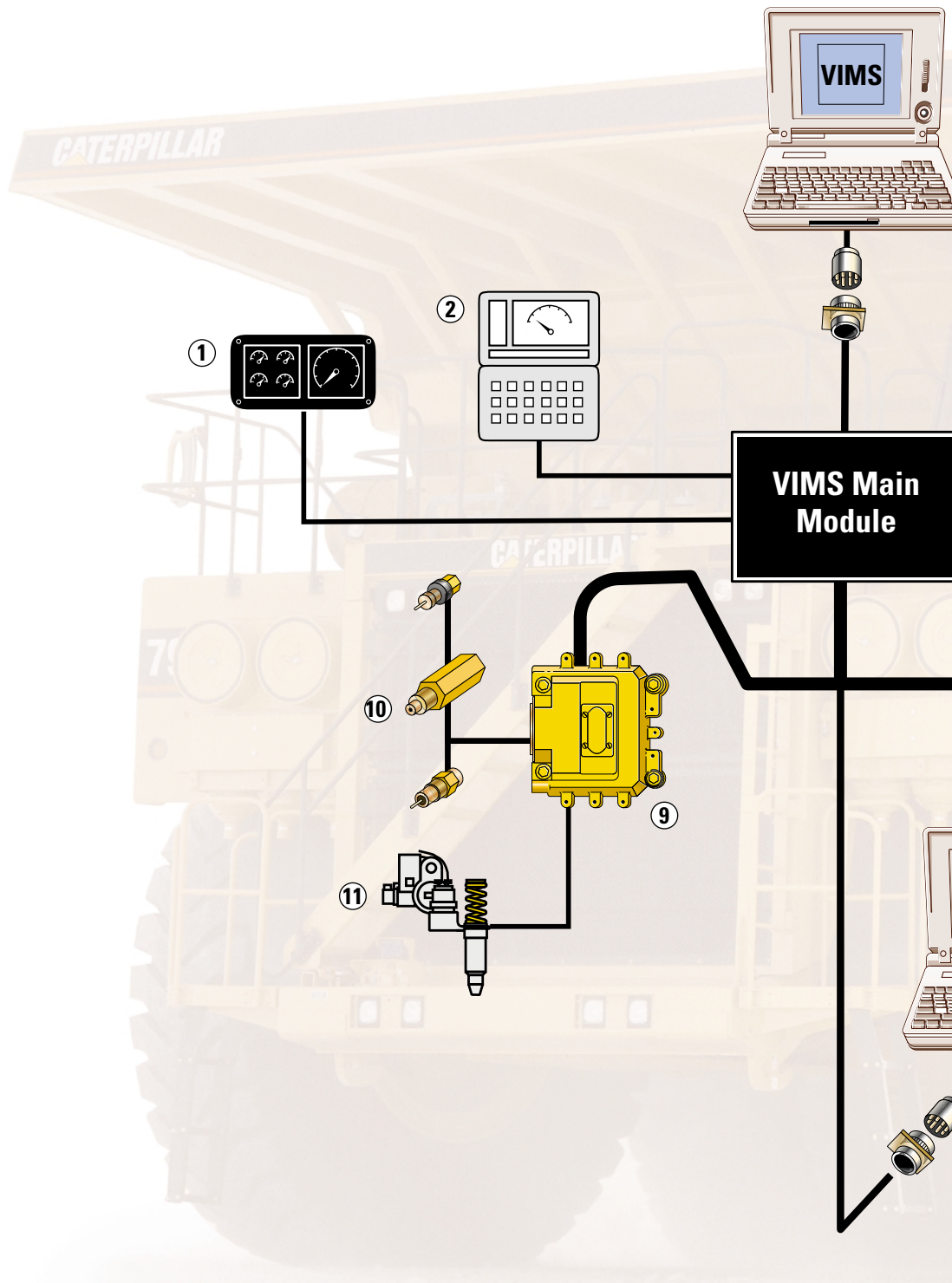

Improved diagnostics/serviceability.

The electronic engine and transmission controls provide enhanced diagnostic capability. The ability to store both active and intermittent indicators will simplify problem diagnosis and total repair time, resulting in improved mechanical availability and lower operating cost.

- **Electronic Technician (ET)** allows for easy access to service diagnostic data through the use of a single service tool.
- ET accesses data stored in the engine and transmission controls via the CAT Data Link. Information on transmission shift data, engine speed, fuel consumption and other data can be retrieved by ET.

Integrated Braking Control (IBC) combines braking control enhancements into one system for efficiency and simplification. IBC systems, Automatic Retarder Control (ARC), and Traction Control System (TCS) both utilize the standard oil cooled disc brakes in their operation.

- 1 Gauge Cluster Module
- 2 Message Center Module
- 3 Integrated Braking Control (IBC)
- 4 Transmission/Chassis Control (TCC)
- 5 Brakes
- 6 Wheel Sensor
- 7 Transmission
- 8 CAT Data Link
- 9 Engine Control Module (ECM)
- 10 Sensors
- 11 Electronic Unit Injector (EUI)

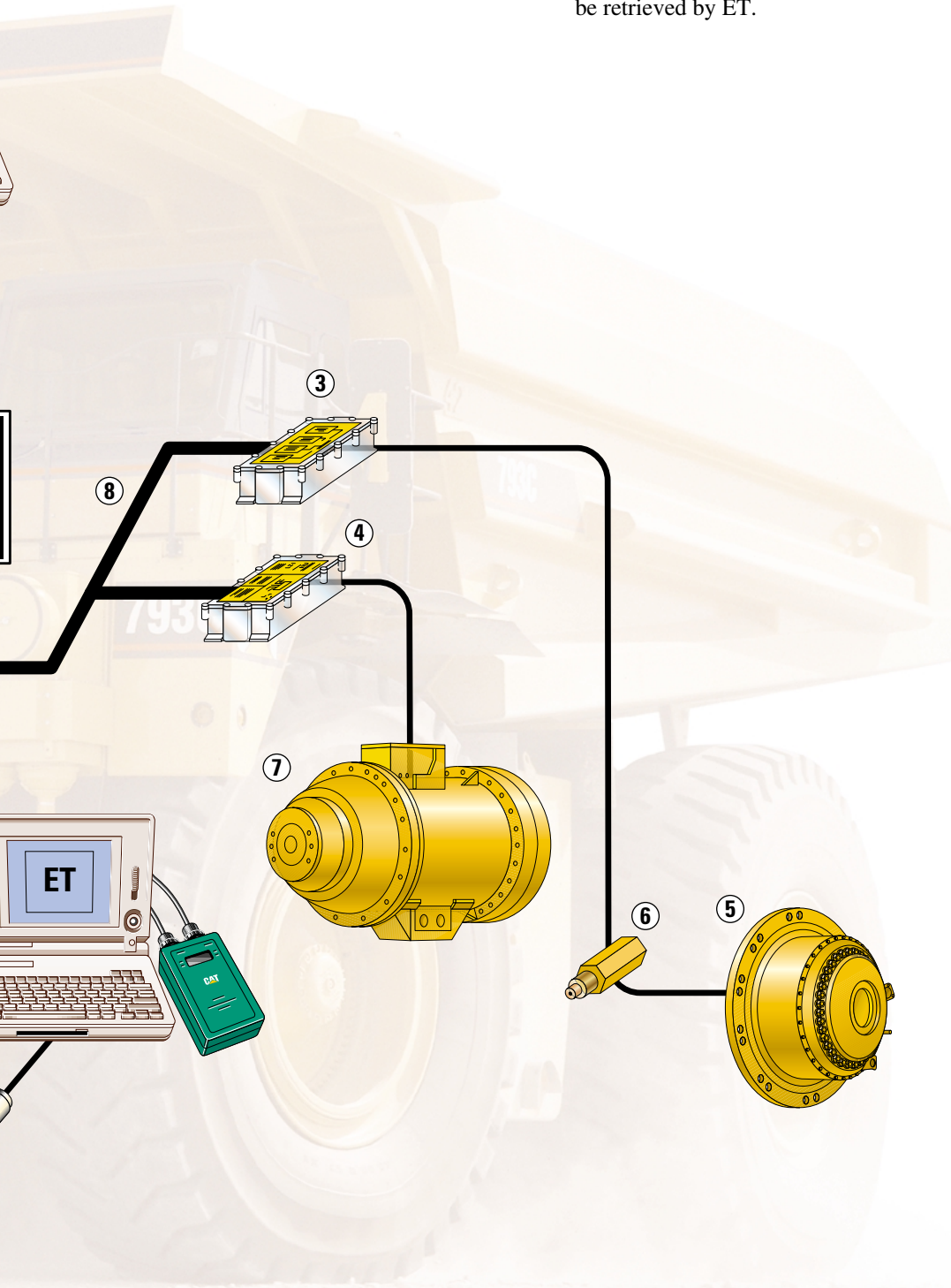

Oil-cooled Disc Brakes

Reliable braking gives operators the confidence to concentrate on truck operation and maximize productivity.

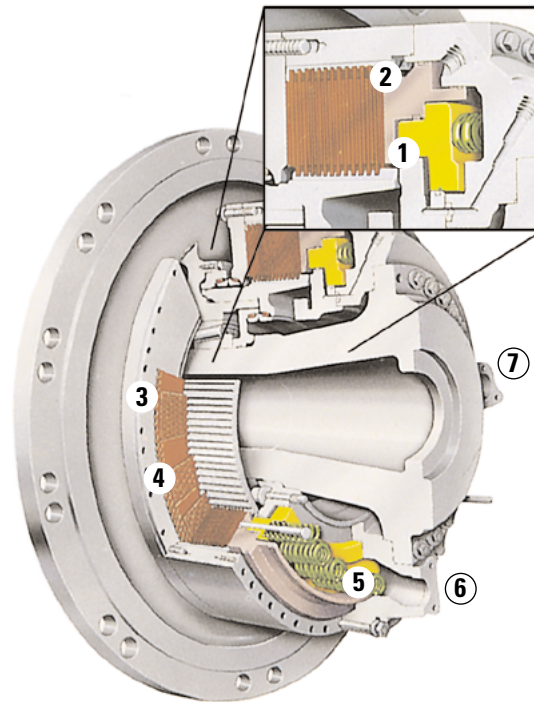

- 1 Parking/Secondary Piston
- 2 Service/Retarding Piston
- 3 Friction Discs
- 4 Steel Plates
- 5 Actuating Springs
- 6 Cooling Oil In
- 7 Cooling Oil Out

Caterpillar four-wheel forced oil-cooled, multiple disc brakes are continuously cooled for exceptional, non-fade braking and retarding. The Integrated Braking Control (IBC) combines control of ARC and TCS, utilizing standard oil-cooled brakes to enhance truck performance and increase productivity.

Oil-cooled disc brakes are designed with large discs and plates for reliable, adjustment-free operation, providing superior performance and service life in comparison to shoe-type and dry disc brake systems.

An oil film prevents direct contact between the discs. The film absorbs the braking forces by shearing the oil molecules. The heat generated is transferred to the oil and carried away to oil coolers, extending brake life.

Caterpillar's patented, two-piston design combines the service, secondary, parking brake and retarding functions in the same robust system.

- **The primary piston** is hydraulically actuated and provides both service and retarding functions.
- **The secondary piston** is spring-applied and is held in the disengaged position by hydraulic pressure.
- The brake system is designed so that, in the event hydraulic system pressure drops below a specified level, the spring-applied secondary piston automatically applies the brakes. These brakes are designed to hold a fully loaded truck on a 15 percent grade.

No fuel is used during retarding. The engine provides additional retarding by running against compression on downhill hauls. During retarding applications the engine ECM does not inject fuel into the cylinders for exceptional fuel economy.

Four corner retarding with 60/40 percent split (rear/front) in braking effort provides superior control in slippery conditions. Control at all four corners increases operator confidence when compared to only rear wheel dynamic retarding systems.

Integrated Braking Control (IBC)

Electronically combines Automatic Retarding Control (ARC) and the Traction Control System (TCS) into one, integrated control system.

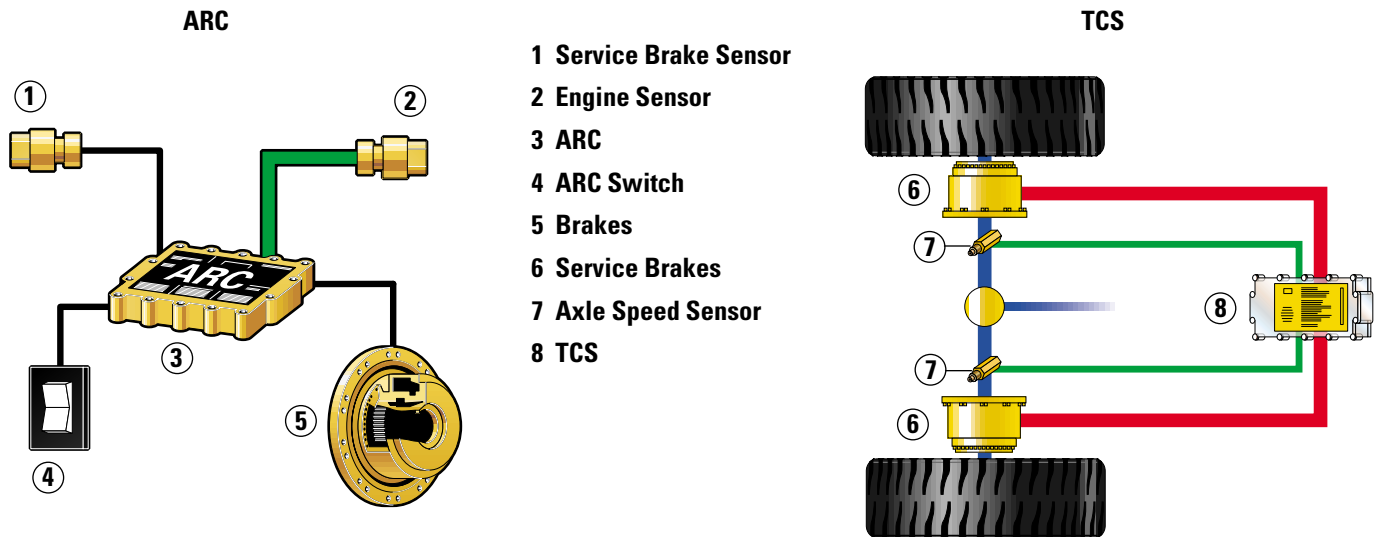

The Automatic Retarder Control (ARC) is an integral part of the intelligent power train. It electronically controls retarding on grade to maintain optimum engine rpm and oil cooling. Settings are adjustable from 1850-1950 rpm in increments of 10 rpm. While ARC modulates the brakes, the operator may also apply additional braking force using either the manual retarder or the brake pedal. When the operator applies the throttle, ARC is deactivated. An auto resume feature reactivates the control without additional operator input.

ARC results in:

- **Increased production** with faster downhill speeds. By maintaining consistently higher engine speeds, overall truck speed will be higher than a manually controlled truck.
- **Excellent controllability and reduced operator effort.** Automatic brake modulation provides a smoother ride, better control in slippery conditions and allows the operator to focus more on driving.
- **Faster troubleshooting and diagnosis** with self-diagnostic capability and the ability to communicate with ET through the CAT Data Link.
- **Reduced operator fatigue** resulting from ease of operation.

- 1 Service Brake Sensor
- 2 Engine Sensor
- 3 ARC
- 4 ARC Switch
- 5 Brakes
- 6 Service Brakes
- 7 Axle Speed Sensor
- 8 TCS

- **Engine overspeed protection.** ARC will automatically activate when engine speed exceeds factory preset levels, regardless of other operator inputs, including when the system is turned “off”, to help ensure that engine overspeed conditions do not occur.

ARC production advantages (versus manual retarder control) are illustrated in the chart below.

- ARC can increase vehicle speed by as much as 15 percent over manual retarder control.
- The system allows trucks to operate at maximum speeds with a consistently high engine speed.
- Truck handling is significantly enhanced through improved retarding modulation.

Traction Control System (TCS) improves traction and truck performance in poor underfoot conditions by electronically monitoring and controlling wheel slippage.

- Axle sensors monitor wheel speed. If slippage exceeds a set limit, the oil-cooled disc brakes engage to slow the spinning wheel. Torque is then automatically transferred to the wheel with better traction.

- Utilizes normal differential action to provide superior maneuvering in poor underfoot conditions. Should the sensors fail, normal differential action is still available to maintain control and steering.
- Operators feel more confident with the anti-slip benefits provided by the TCS.

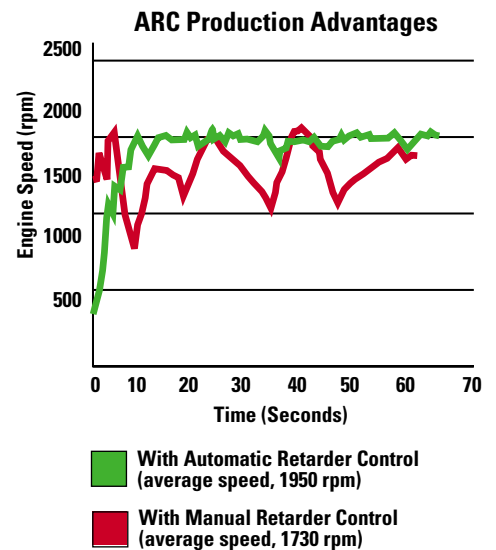

Structures

The backbone of the Cat truck.

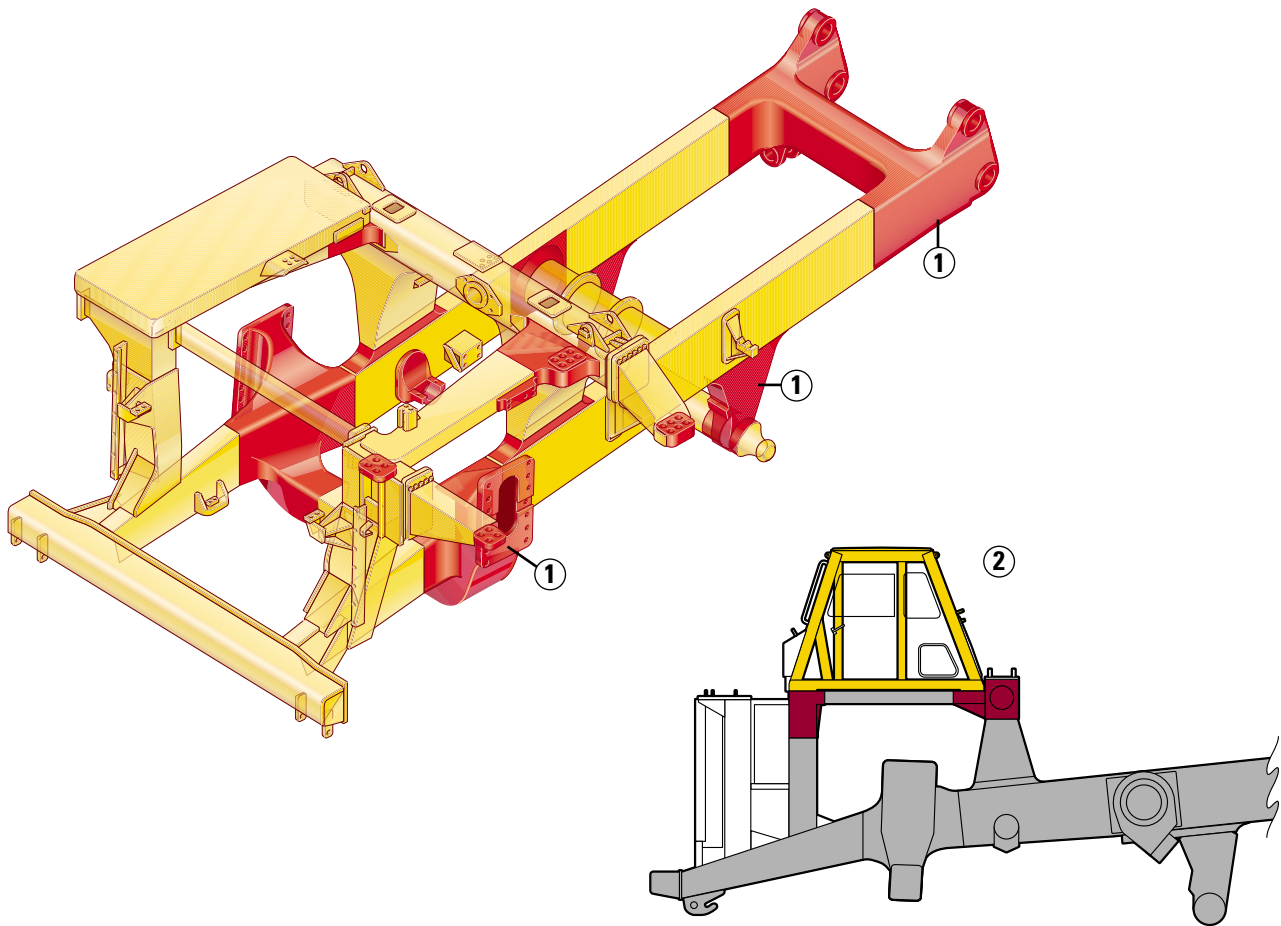

Box-section frame design and deep penetrating, continuous welds resist damage from heavy loads without adding extra weight. Frame repairs can be made without preheating in ambient temperatures above 16° C (60° F), avoiding metallurgy degradation.

- Caterpillar truck frames use mild steel providing flexibility, durability and resistance to impact loads even in cold climates.
- The frame incorporates two forgings and 22 castings in high stress areas, providing two to three times the strength of equivalent-sized fabricated structures.

1 Castings have large radii with internal reinforcing ribs to dissipate stresses that can cause fatigue and cracking:

- Welds are placed in areas of lower stress to enhance frame life.

2 Rollover Protection Structure (ROPS) is integral to the cab and frame. The cab is resiliently mounted to the frame to reduce vibration and noise levels.

The suspension system is designed to dissipate haul road and loading impacts:

- Four independent variable rebound suspension cylinders absorb shocks before forces get to the mainframe. This extends frame life and provides the operator a more comfortable ride.

- Rear cylinders allow axle oscillation and absorb the bending and twisting stresses caused by uneven and rough haul roads rather than transmit them to the main frame.

- Front cylinders are mounted to the frame and serve as steering kingpins. This provides for a tight turning radius, good maneuverability and reduced truck maintenance. Front spindles and wheels are rigidly mounted to the cylinder rod ends, eliminating caster and camber adjustments.

- Front wheel caster and camber are set at the factory, no longer requiring field adjustments.

Truck Body Systems

Caterpillar builds a variety of rugged, durable bodies to perform in the toughest mining applications.

1 Dual-slope body design provides excellent load retention, a low center of gravity and clean dumping characteristics.

- **Reinforced, rolled steel top rail** increases body strength and protects the body from damage.
- Eight degree “V” reduces shock loading and helps center the load.
- 7.5 degree forward body slope and 16 degree ducktail slope helps retain loads on steep grades.
- **Box-beams** in floor, sidewalls, top rail, corner and cab canopy areas provide added impact resistance.
- 400 Brinell steel on interior surfaces.

2 Flat floor body design provides smooth, metered dumping and higher dump clearances.

- Flat floor design improves the wear characteristics in the rear of the body.
- 12 degree forward slope for good load retention.
- 400 Brinell steel on interior surfaces.

3 Mine Specific Design (MSD) bodies, specifically designed for each application, are available as a custom configuration to minimize weight and maximize productivity.

- Caterpillar design engineers will visit the mine site, study the Truck Body Profile, and determine the optimum body design.
- Interior of body is constructed with WearMaster 138 steel, exclusive to Cat, for superior wear and impact resistance.
- All new MSD bodies will include a pair of external digital displays.

Custom truck body options are available to match individual mine applications. Your Caterpillar Dealer, through CMT Custom Products, can provide a body system that will help you obtain the lowest cost-per-ton hauling solution.

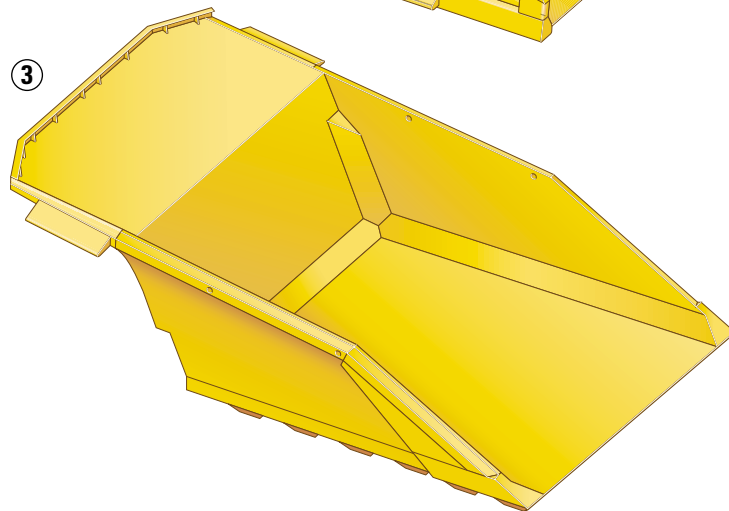
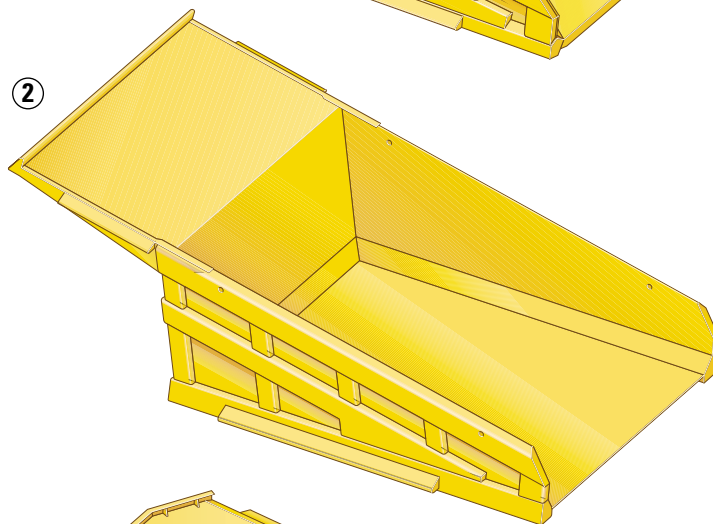
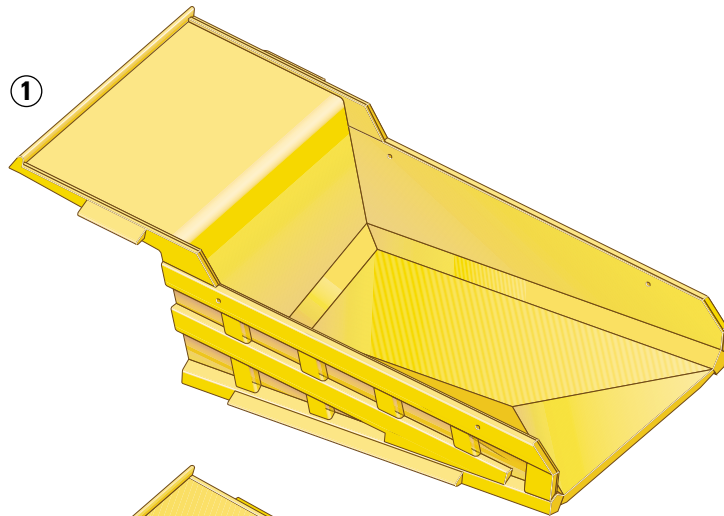

Miscellaneous products including wraparound tail extensions, sideboards, rock shedders, tumblebars, rockboxes, and liners are also available.

A variety of steel grades and overlay coatings are available, including Brinell hardness 400, 450, and 500.

Wear plates can be added where required, including the Caterpillar Mechanically Attached Wear Protection System (MAWPS).

Operator's Station

Control the truck with ease and comfort to maximize productivity.

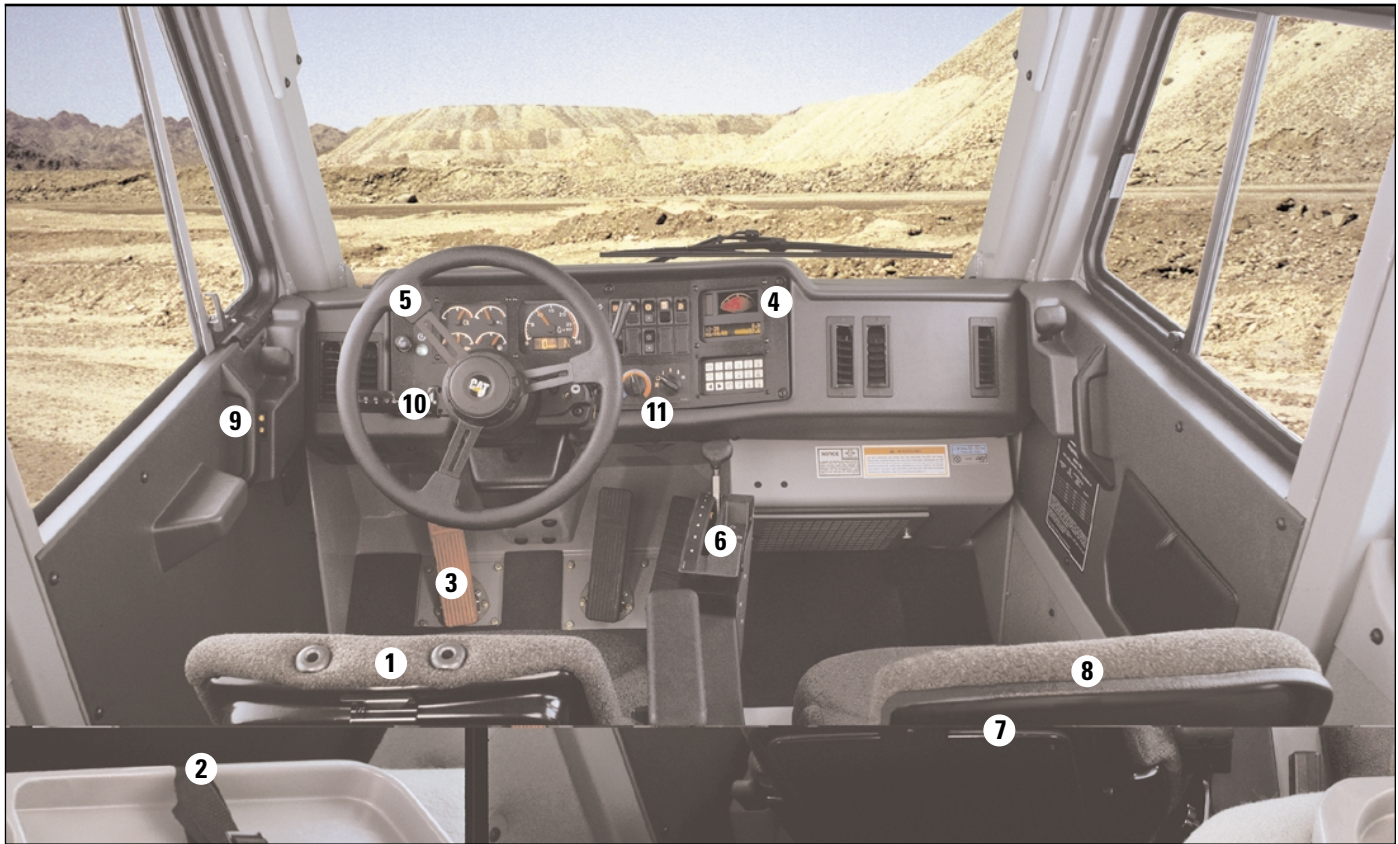

The 793C operating station is ergonomically designed for excellent machine control in a comfortable, productive and safe environment.

Exceptional all-around visibility reduces strain and fatigue allowing confident maneuverings and increased productivity.

Integral, sound-suppressed ROPS/FOPS Cab is standard and meets ROPS criteria SAE J1040-MAY94. The cab is resiliently mounted to the mainframe and isolates the operator from sound and vibration. (Sound levels are less than 80 dB(A) in the operator compartment as per SAE J1166-OCT98 work cycle rating specified in ISO 6394.)

1 Ergonomically designed, air suspension seat is fully adjustable for operator comfort.

- Retractable 75 mm (3") wide seat belt provides positive, comfortable restraint.
- Integral adjustable armrest.

2 Electric hoist control is mounted next to the operator's seat for ease of operation. This is a low effort control to minimize operator input.

3 Secondary brake pedal is located on the floor to provide easy operator control.

4 VIMS displays and operator key pad for precise machine status information.

5 Tilt and telescoping steering wheel improves operator access and comfort.

6 Transmission console has been redesigned with backlit gear indicators and ergonomic shift knob.

7 Large storage compartment is located under the trainer seat.

8 Trainer seat has wide hip and shoulder room. A back rest and seat belt are standard. An optional air suspended seat is available.

9 Powered operator window is standard. Sliding trainer seat window is standard.

10 Operator controls for turn signal, high beam, intermittent windshield wiper, windshield washer and horn have been redesigned for operator efficiency and comfort.

11 Standard heater and air conditioner have a more efficient design, permitting increased flow, modulation, and serviceability. These systems provide fresh, pressurized, temperature-controlled air circulation.

Radio ready cab prewired with power converter, speakers, wiring harness, and antenna. Provision for add-on communication systems.



Vital Information Management System (VIMS)

Provides operators, service technicians and managers with vital machine and production data.

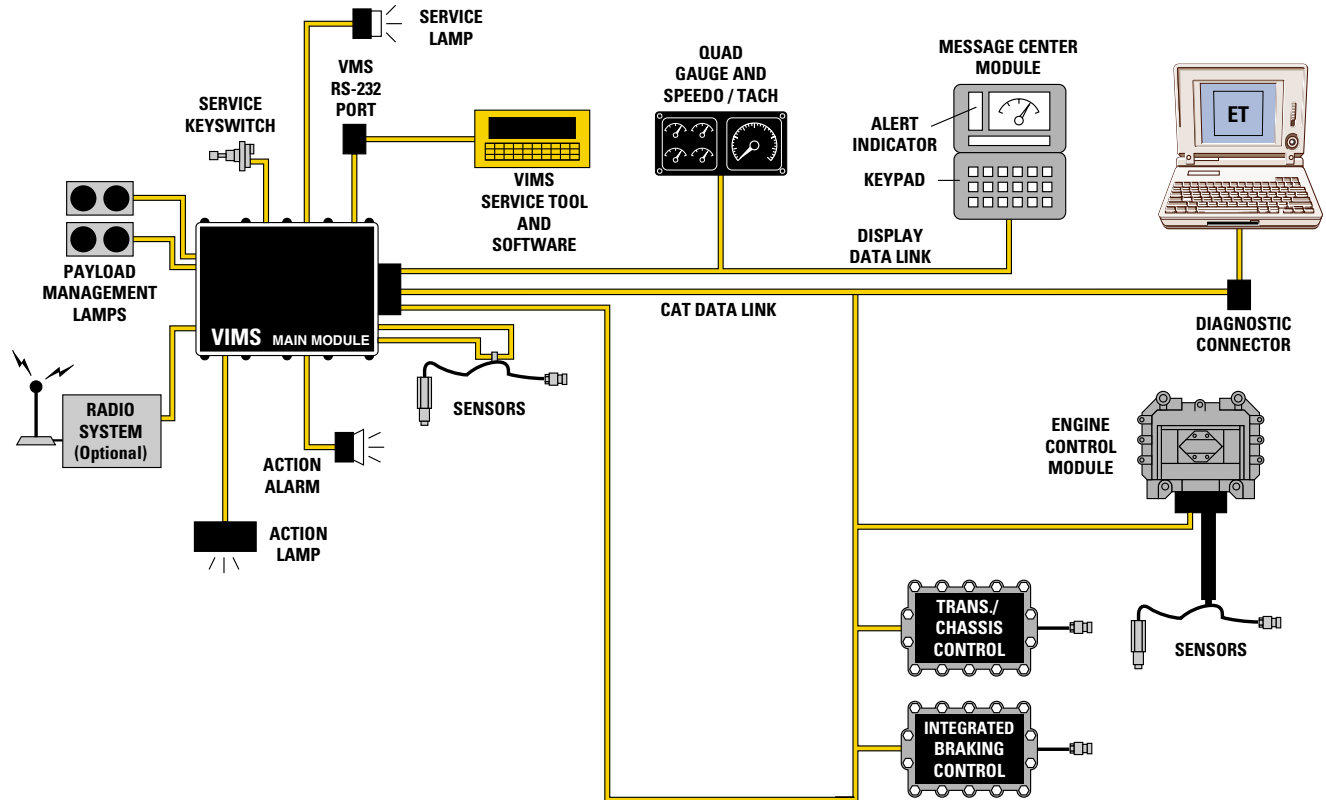

VIMS is an integrated Caterpillar-designed system that monitors machine performance to provide critical information on a real-time basis. VIMS monitors many of the machine's systems through a single simple system that allows quick exchange of information for smooth, efficient operations. This helps keep the 793C performing at top production levels.

Gauge cluster in the cab maintains a constant display of several, machine functions:

- Engine coolant temperature.
- Brake oil temperature.
- Air system pressure.
- Fuel level.

Speedometer/Tachometer/Gear Indicator.

VIMS keypad allows the operator or service technician to access through the message center, gauge values (real-time) and stored information. The keypad can also be used by service personnel to access diagnostic information.

Message center displays operator requested information and utilizes a three-category warning system to alert the operator to an abnormal machine condition.

The three-category alert system provides advisory information on an exception basis to the operator via the message center on abnormal machine conditions. The information is displayed when conditions in a monitored system fall outside a prescribed setting for ordinary operations.

- **Category I** activates the alert indicator lamp when a system condition has been identified. (*No action is required at this time.*) Usually all that is required is to inform service personnel on the alerted condition as soon as possible.
- **Category II**, a warning lamp (located above the gauge cluster) flashes in addition to the Category I alert indicator lamp in the display panel. Instructions are displayed on how machine operation should be modified or which service should be performed.
- **Category III**, the highest alert, sounds an audio action alert in addition to the Category II alarms. The action lamp and alert remain on until the system readings return to normal or the machine is shut down.

Vital Information Management System (VIMS)

Enhances truck and loader effectiveness for improved fleet productivity and reduced operating and maintenance costs.

VIMS simplifies trouble shooting,

reduces down time and lowers operating costs by allowing minor problems to be corrected before they cause extensive damage. Many sensors are incorporated into machine systems to monitor conditions.

Production management, a feature component of VIMS, enhances truck and loading tool effectiveness for improved fleet productivity and reduced operation and maintenance cost.

- Maximizes truck production while avoiding future costs and downtime related to overloading.
- External lights on both sides of the truck signal loading tool operator when to cease loading.
- Stores 2400 cycles for a record of payload weight, cycle segment times, cycle segment distances and actual clock time and date of each cycle.
- Data can be accessed through the message center, transmitted via optional radio or downloaded for detailed analysis.
- Accurate to within ± 5 percent of the actual weight over a normal operating shift.
- **True Weight Production Management System** utilizes suspension strut pressure differentials and a new algorithm to weigh the truck after it has moved away from the loader and has shifted into second gear. This new system filters out many anomalies with loading that led to inconsistencies with previous systems.
- **Road Analysis Control (RAC)** (optional attachment) utilizes suspension strut pressure differentials to monitor haulroad conditions for operation and maintenance management.

Payload Weight Distribution

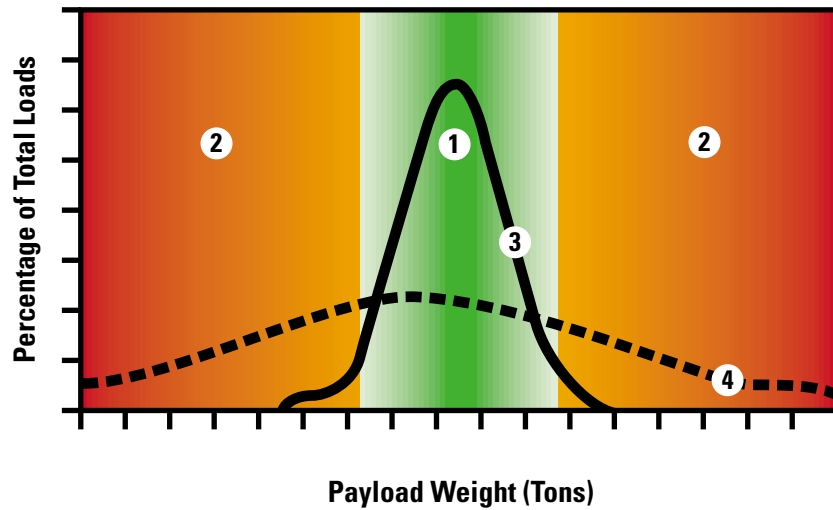

- ① Recommended Payload Ranges
- ② Inefficient Payload Ranges
- ③ Loads using the Payload Measurement System ———
- ④ Loads with no Payload Measurement System - - -

The VIMS off-truck software program (VIMS-PC) allows service personnel to download a complete record of production information, machine data events and system diagnostics to a laptop computer.

The VIMS-PC program uses this information to generate usable reports for better machine management. The information can also be used to establish a baseline for machine performance in specific applications, and to:

- Improve the effectiveness of scheduled maintenance programs.
- Maximize component lives.
- Improve machine availability.
- Lower cost-per-ton.

Well-managed mining operations focus on maximizing production and reducing costs, which should result in lower cost-per-ton. When used properly, VIMS can be used to increase productivity and reduce costs.

Total Customer Support and Serviceability

Caterpillar machines are designed to spend less time down for maintenance, allowing more time on the job.

Parts availability. Most Cat parts are immediately available off the shelf. Cat Dealers rely on our worldwide computer network to find parts instantly and minimize your machine downtime.

Flexible financing. Your dealer can arrange attractive financing on the entire line of Cat equipment.

Machine management service. Cat Dealers help manage your equipment investments with:

- Vehicle systems analysis to match the right machine to your job conditions.
- Effective preventive maintenance programs.
- Diagnostic programs like Scheduled Oil Sampling Analysis and Technical Analysis.
- Exchange components for quick repairs.
- Remanufactured products or rebuilt components for maximum availability and lower costs.
- Information to make the most cost-effective repair option decisions.
- Training for operators and mechanics.

Literature support. Operation and maintenance manuals are easy to use helping you get the full value of your equipment investment.

Remanufactured components are economically available for many Caterpillar components.

Ground-level access provides convenient servicing to tanks, filters and compartment drains, as well as engine shutdown capability. VIMS has a ground-level access port for easier downloading of information.

Caterpillar Electronic Technician (ET) accesses machine data easily. It quickly runs tests, makes calibrations and retrieves system data to help find and correct problems before they become costly failures.



The maintenance platform provides access to engine, air filters, steering hydraulic tank and battery compartment.

Automatic lubrication system provides grease to necessary components on a regular basis to reduce maintenance and improve machine availability.

Fast fill service center (Wiggins) features high speed fuel and oil exchange.

S•O•SSM oil analysis speeds sampling and analysis reliability.

Oil Renewal System (ORS) is an option available which extends oil change intervals and reduces waste oil handling by continuously burning oil from the sump through normal engine operation. Make-up oil must be added to compensate for oil burned (CG-4 oil required).

Individual, interchangeable engine cylinder heads can be removed easily for visual inspection of internal parts.

In-frame access allows maintenance and minor repairs without major component removal. It also facilitates major component removal and replacement, if necessary.

Quick coupler pressure taps are located in most hydraulic systems providing clear, quick pressure checks and diagnostics.

Radial seal air filters are easy to change, reducing time required for air filter maintenance.

Sealed electrical connectors lockout dust and moisture. Wires are color coded for easy diagnosis and repair. Wiring harnesses are braided and have a protective sheath to prevent damage.

Engine

3516B Series, 16 cylinder, four-stroke cycle, diesel engine.

Ratings at 1750 rpm* ▲	kW	hp
Gross power	1715	2300
Net power	1615	2166

The following ratings apply at 1750 rpm when tested under the specified standard conditions for the specified standard:

Net power ▲	kW	hp
Caterpillar	1615	2166
ISO 9249	1615	2166
SAE J1349	1599	2144
EEC 80/1269	1615	2166

3516B Dimensions

Bore	170 mm	6.7 in
Stroke	190 mm	7.5 in
Displacement	69 liters	4,211 in ³

- no derating required up to 3600 m (12,000 ft) altitude

3516B High Displacement Dimensions

Bore	170 mm	6.7 in
Stroke	215 mm	8.5 in
Displacement	78 liters	4,763 in ³

- no derating required up to 2750 m (9,000 ft) altitude

▲ - Denotes common to both 3516B and 3516B HD Engines

*Power rating conditions

- based on standard conditions of 25° C (77° F) and (29.32 in Hg) dry barometer

- used 35° API gravity fuel having an LHV of 42,780 kJ/kg (18,390 Btu/lb) when used at 30° C (86° F) [ref. a fuel density of 838.9 g/L (7.001 lb/U.S. gal)]
- net power advertised is the power available at the flywheel when the engine is equipped with fan, air cleaner, muffler and alternator
- automatic derate is included in the electronic controls

Features

- full electric control
- high pressure unit injection
- two hard faced intake and two exhaust valves per cylinder with valve rotators and hard, alloy-steel seats
- self-aligning roller followers on cam shaft
- two-piece pistons have steel crowns, thermally isolated aluminum skirts, three rings each and are cooled by dual oil spray
- steel backed, copper-bonded crankshaft bearings
- hardened crankshaft journals
- dry-type air cleaners with primary and secondary elements and precleaner
- 24-volt electric system with 105-amp alternator and two 93-amp-hour, low-maintenance, high-output, 12-volt batteries

Brakes

Meets the J-ISO 3450 JAN88, ISO 3450-1996 standards up to 384 000 kg (846,000 lb) gross machine operating weight.

Braking surface 224 317 cm² (34,769 in²)

Features

- service brakes
 - forced oil-cooled
 - air-over-oil actuated
 - front and rear disc brakes
 - sealed from dirt and water
 - individually serviceable as units
- parking brakes
 - spring-engaged, hydraulically released
 - use same disc brakes as service system
 - toggle switch activated
- secondary braking
 - spring-engaged, hydraulically released
 - use same disc brakes as service system
- retarding system
 - hand operated friction lever provides modulated engagement of service brakes for retarding
 - retarding applied to all wheels (40/60 split, front rear)
 - Automatic Retarder Control standard
- traction system
 - minimize wheel slip by transferring torque to wheel with traction
 - Traction Control System (TCS) standard

Transmission

Caterpillar six-speed, electronically controlled, automatic power shift transmission.

Maximum travel speeds (40.00R57 tires)

		Radial		
		km/h	mph	engine rpm
Forward	1	11.8	7.3	@1960
	2	15.9	9.9	@1960
	3	21.5	13.4	@1960
	4	29.0	18.1	@1960
	5	39.4	24.5	@1960
	6	54.3	33.7	@2000
Reverse		10.9	6.8	@1960

Features

- six speeds forward and one reverse
- reverse and first gear are both torque converter driven with lock-up in first through sixth gears
- single-lever shift control provides automatic shifting in all gears up to the one selected by the control lever

- each shift is individually modulated for maximum smoothness
- shared oil circuit with torque converter
- Controlled Throttle Shift and Directional Shift Management maximize shift smoothness and minimize shift driveline stress
- electric control has built-in diagnostics and fault code memory, event memory and programmable features

Frame

Full box-section with torque tube crossmember.

Features

- integral front bumper
- front box beams for suspension cylinder and ROPS support
- box-section upper crossmember for body and ROPS support with attachment points for maintenance platform and rear engine hood hinge support
- castings are used to provide additional strength in critical stress areas
- mild-steel plates (310 mPa/42,000 psi minimum yield strength) and castings (241 mPa/35,000 psi minimum yield strength) provide:
 - flexibility
 - durability
 - good resistance to impact loads

Suspension

Independent, self-contained, oil-pneumatic suspension cylinder on each wheel.

Features

- variable rebound rate reduces impact and smooths ride
- front suspension cylinders are bolted to upper and lower frame members for maximum support
- rear sway bar attaches to frame and differential housing, minimizes lateral sway, improves machine handling and operator comfort

Effective cylinder stroke:

Front	318 mm	12.5"
Rear	165 mm	6.5"
Rear axle oscillation		±4.9°

Exterior Sound Rating

- The machine in a standard configuration, when measured and operated as per the prescribed modes in ANSI/SAE J88 JUN86, has a 15 m sound pressure level of 89 dB(A) for the mode that gives the highest level

Body Hoists

Twin, two-stage hydraulic cylinders mounted outside the main frame.

Features

- pump capacity is 739 L/min (195 gpm) @ 1750 rpm
- relief valve setting is 203.3 bar/20 326 kPa (2950 psi)
- body raise time (1960 engine rpm) is 20.25 sec.
- body lower time:
 - @ 700 rpm, low idle
 - power down 19.25 sec.
 - float down 19.26 sec.
 - @ 1960 rpm, high idle
 - power down 17.51 sec.
 - float down 19.26 sec.
- power raise in both stages and power down in first stage
- pump flow at high idle is 826 L/min (218 gpm)
- automatic body-lower modulation to reduce impact on frame

ROPS

Integral ROPS cab is standard.

Features

- ROPS offered by Caterpillar for the machine meets ROPS criteria: SAE J1040 APR88, SAE J231 JAN81, ISO 3471-1994, ISO 3449-1992 LEVEL II
- when correctly installed and maintained, the cab offered with doors and windows closed as per work cycle procedures specified in ANSI/SAE J1166 MAY90, results in an operator sound exposure Leq (equivalent sound level) of less than 80 dB(A)
- this operator weighted sound exposure meets OSHA and MSHA occupational noise exposure criteria

Final Drives

Double-reduction, planetary, with full-floating axles.

Ratios:

Bevel Gear (differential)	1.8:1
Planetary (final drive)	16:1
Total reduction	28.8:1

Steering

Separate hydraulic system.

Features

- the steering hydraulic system is separate from the main hydraulic system to prevent cross-contamination
- secondary steering is provided by a bladder-type accumulator
- twin, double-acting cylinders
- front suspension cylinders serve as kingpins
- normal and secondary steering systems meet SAE J1511 OCT90 and ISO 5010-1984 standards up to gross machine operating weight 384 000 kg (846,000 lb.)
- turning diameter on front wheel track 28.4 m (93' 3")
- machine clearance turning circle 32.4 m (106' 4")
- steering angle (left or right) 36°

Body

Dual slope, flat floor and Mine Specific Design (MSD) bodies are available.

Features

- high tensile, heat-treated steel plates are utilized in the sidewalls, front wall, and floor of all bodies
- exhaust heating is available
- body size is determined by the material being hauled

NOTE: A variety of bodies specifically designed for each unique application are available. Consult your Cat dealer to determine the most cost-effective body for your application.

Tires

Standard: 40.00R57.

Optional: 44/80R57*, 44/95R57*, 46/90R57.

Features

- productive capabilities of the 793C Truck are such that, under certain job conditions, TKPH (Tmph) limits of the tires could be exceeded and, therefore, affect production
- Caterpillar recommends the user evaluate all job conditions and consult the tire manufacturer to make proper tire selection

* - Requires rear axle wide tire kit (no additional weight)

Dimensions

All dimensions are approximate

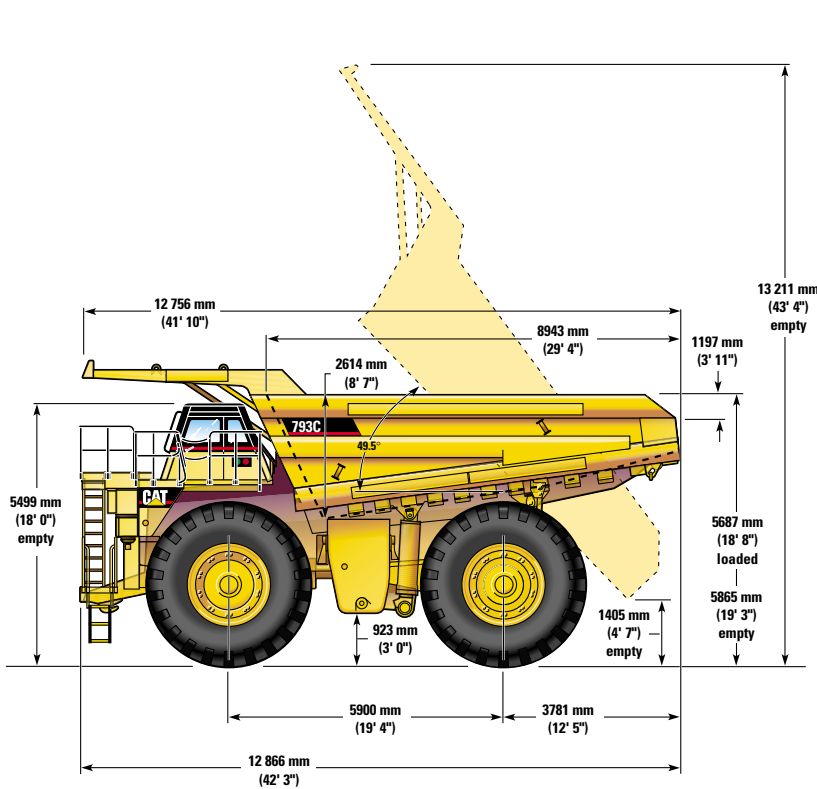

NOTE: Standard, dual-slope body shown.

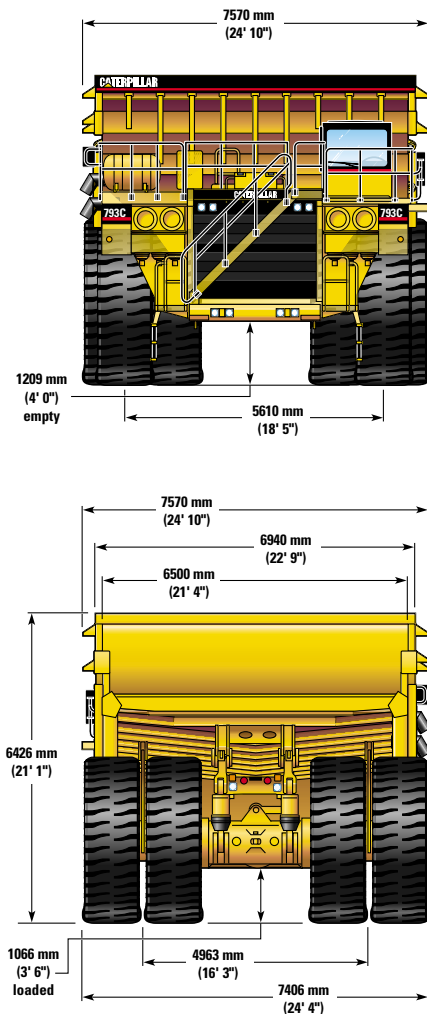

Service Refill Capacities

	L	U.S. Gallons
Fuel tank	3790	1000
Cooling system	684	181
Crankcase	291	77
Differential	662	175
Front Wheels, each	21	5.5
Final Drives, each	114	30
Steering Tank	130	34
Steering System (includes tank)	189	50
Brakes and Hoist Tank	580	153
Brakes and Hoist System (includes tank)	1137	300
Torque Converter Sump	87	23
Torque Converter and Transmission System (includes sump)	227	60

Weights

(approximate)

Standard vehicle:	kg	lb
Chassis with hoist, body mounting group and tires	114 300	252,000
Body weight	*	*

* - body weight varies from 21,795 to 54,431 kg (48,050 to 120,000 lbs) — depending on how body is equipped

Gross machine operating weight	384,000	846,000
Weight distribution:		
	Empty	Loaded
Front Axle	46.9%	33.3%
Rear Axle	53.1%	66.7%

NOTE: Refer to page 23 for weight / payload calculation example.

Gradeability/Speed/Rimpull

To determine gradeability performance:
 Read from gross weight down to the percent of total resistance. Total resistance equals actual percent grade plus one percent for each 10 kg/t (20 lb/U.S. ton) of rolling resistance.
 From this weight-resistance point, read horizontally to the curve with the highest obtainable gear, then down to maximum speed. Usable rimpull will depend upon traction available and weight on drive wheels.

- Typical Field Empty Weight
- Gross Machine Operating Weight
 384 000 kg / 846,000 lb

40.00R57 Tires 1707 mm (67.2") Radius Gross Weight

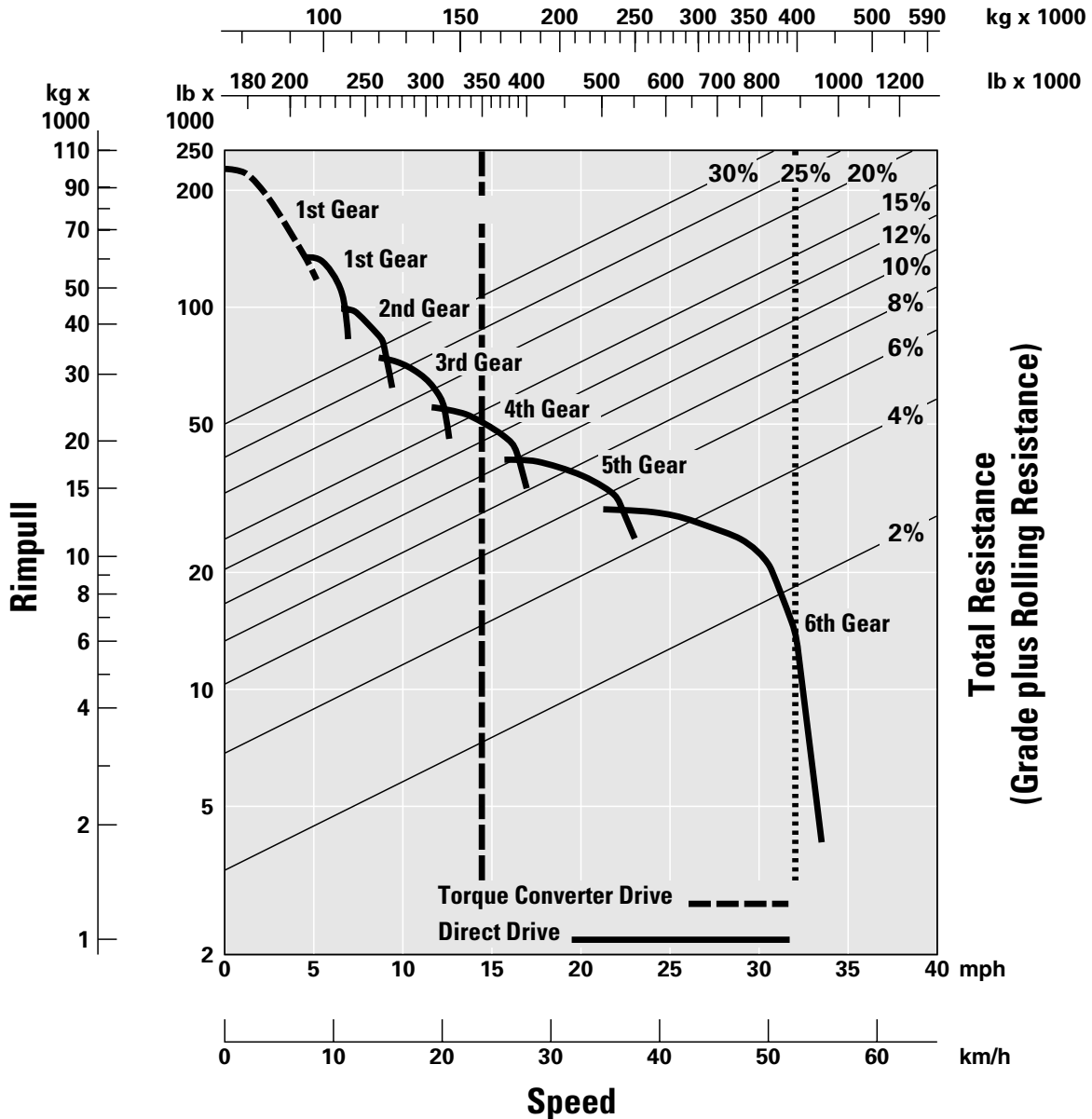

Retarding Performance

Use of Brake Performance Curves

The brake performance “retarding” curves shown in this section are for general guidance only, and assumes that the **Automatic Retarder Control (ARC)** feature is applied at all times. As each site has many unique environmental and operating conditions that will impact retarding performance, actual site performance could vary considerably from predicted performance. Users should use the retarding speed (gear) recommendations from these tables as a starting point for determining retarding performance, and then adjust retarding speeds to their site specific conditions. In adjusting retarding performance to continuously changing environmental and site specific conditions, users need to exercise care to maintain brake cooling and machine controllability at all times.

To determine brake retarding performance from performance tables:

1. Determine the total distance of all downhill grades combined for a given haul profile. This total distance determines the appropriate retarding table (continuous or one of the grade distance tables) applicable to your haul profile.

2. Read from the appropriate gross weight down to percent favorable effective grade. (For these retarding charts, effective grade equals the maximum grade of all downhill haul segments minus rolling resistance — Do not use an average grade value.)
3. From the intersection of the gross weight and effective grade line point, read horizontally to the appropriate gear curve. If the horizontal line intersects two gear curves, choose the first gear curve that the horizontal line intersects (reading from right to left) and read the retarding speed performance immediately below this point. If the intersection point falls on a vertical line between two gears, choose the lowest of the two gears to allow for higher engine RPM thus maximizing brake cooling capacity.
4. Adjust recommended retarding speeds to site specific (environmental and operational) conditions. If the brake system overheats (as indicated by various overheat event indicators reported through VIMS) or specific site conditions dictate (tight turns, short steep grades, manual braking, etc.), reduce ground speed to allow the transmission to shift to the next lower speed range.

- - - - - Typical Field Empty Weight
 Gross Machine Operating Weight
 384 000 kg / 846,000 lb

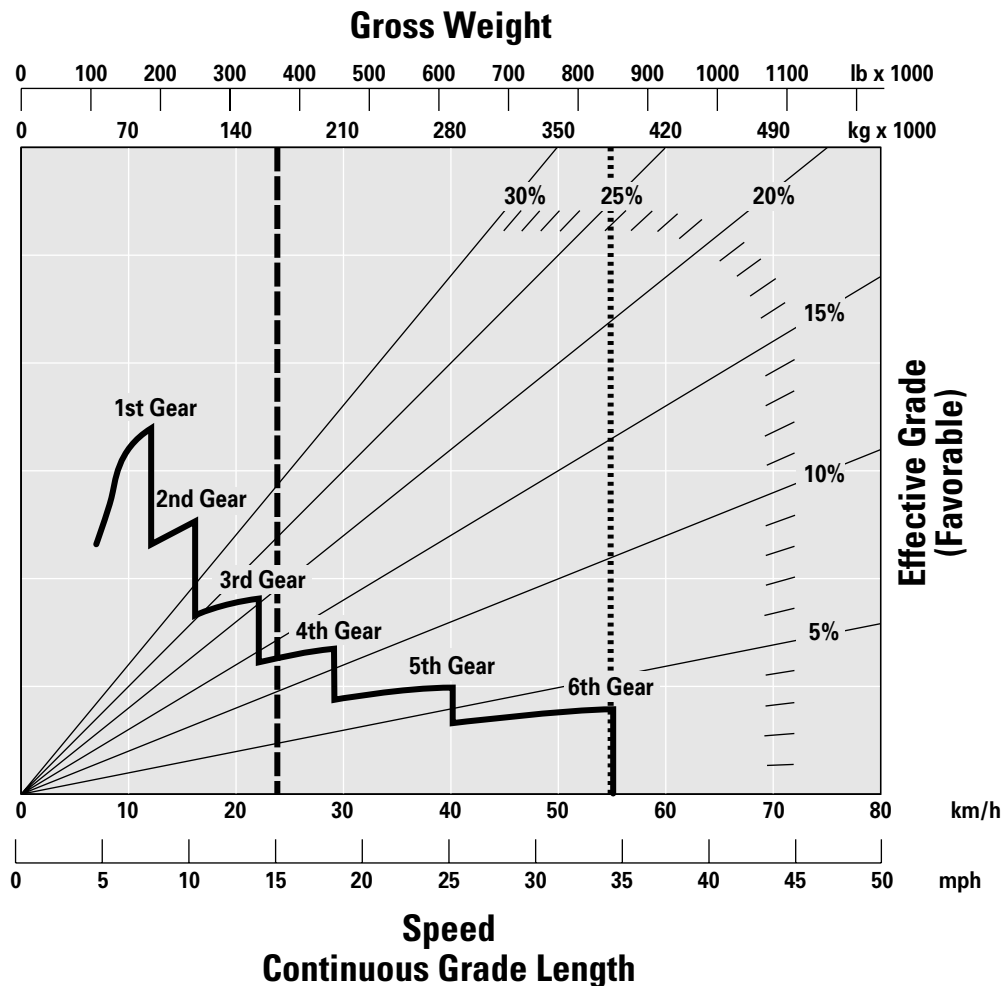

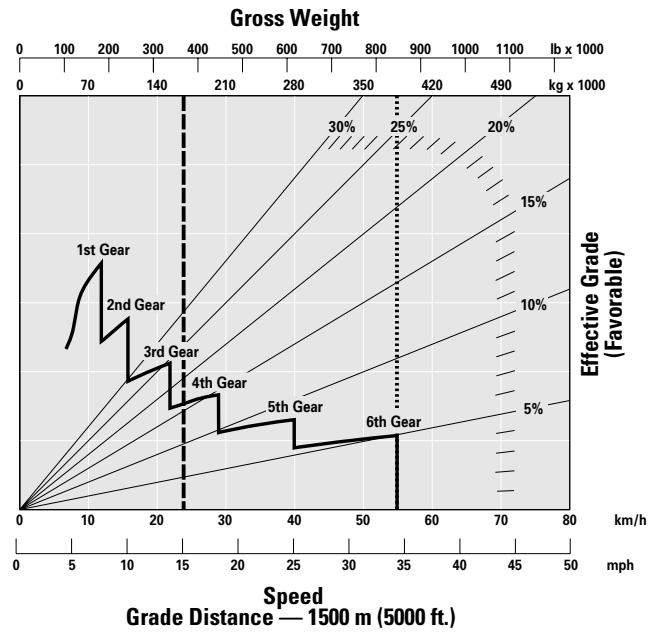
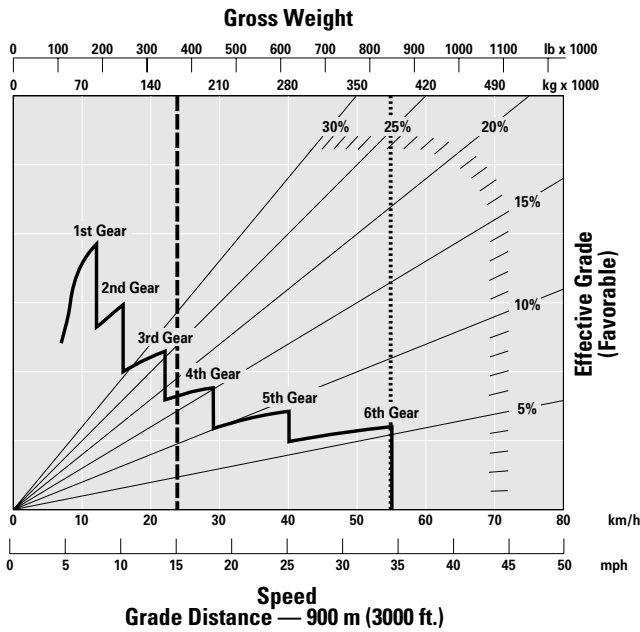
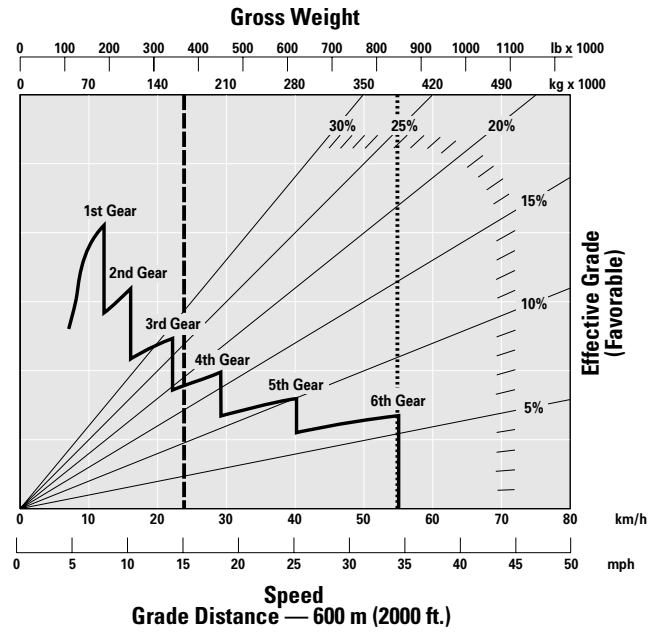
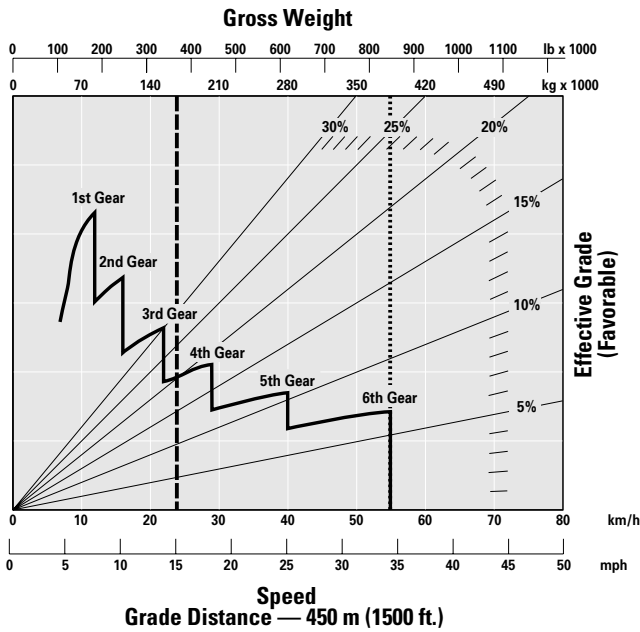

Standard Equipment

Standard equipment may vary. Consult your Caterpillar Dealer for specifics.

Air cleaner (4)	Seat, passenger, with storage area	Oil change system, quick service
Air cleaner access platform	Speedometer	S•O•S Sampling Valves
Air conditioner	Steering, automatic supplemental	Reservoirs (separate):
Air line dryer	Steering wheel, tilt and telescoping, padded	Brake/hoist
Alarm, backup	Storage compartment	Steering
Alternator (105-amp)	Sun visor	Transmission/torque converter
Automatic Retarder Control	Tachometer	Rims, center mounted for
Batteries, 93-amp-hour, low- maintenance, 12-volt (2)	Transmission gear indicator	40.00R57 tires
Body mounting group	VIMS dataport (2)	Rock ejectors
Body prop cable	VIMS keypad	Starting aid, ether, automatic
Brake release motor for towing	VIMS message center with Universal Gauge	Steering, auxiliary quick connect for towing
Brakes system:	Windshield wiper and washer	Tie down eyes
Oil-cooled, multiple-disc, front and rear	Crankcase protection	Tow hooks, front
Parking	Driveline operator safety guard	Tow pin, rear
Secondary, emergency	Dumping, auxiliary quick connect for "buddy dumping"	Traction Control System
Cab, ROPS:	Electrical system, 24-volt to 12-volt	Transmission, six-speed, automatic power shift, electronic control provides Directional Shift
Ashtray	Engine – Caterpillar 3516B with Electronic Injection and Multi Point	Management, Controlled Throttle
Cigarette lighter	Oil Pressure Sensing	Shifting, downshift inhibitor, reverse neutralizer during dumping, neutral
Coat hook	Fast-fill fuel system, Wiggins	start switch, reverse shift inhibitor, neutral coast inhibitor and body-up
Diagnostic connector	Ground level:	shift inhibitor
Electric window (operator only)	Battery disconnect	Vandalism protection locks
Glass, tinted	Engine shutdown	Vital Information Management System with True Weight Production
Heater/defroster:	VIMS Dataport	Management
11 070 kCal (43,930 Btu)	Lighting system:	
Horn	Backup lights, halogen	
Insulated and sound suppressed	Direction signals/hazard warning (rear halogen)	
Light, dome and courtesy	Headlights, halogen, with dimmer	
Mirrors, right and left	LH ladder light and service deck lights	
Quad-Gauge Panel:	Under-hood light	
Air pressure	Stop and tail lights (LED)	
Brake oil temperature		
Coolant temperature		
Fuel level		
Seat belts, 75 mm/3" wide		

Optional Equipment

With approximate changes in operating weights.

Standard equipment may vary. Consult your Caterpillar Dealer for specifics.

	kg	lb		kg	lb
External payload display	55	121	Retractable visor	1	2
Fuel tank (4731 L/1250 gal.)	360	791	Rim, spare for 40.00R57 tire	1512	3,334
Heater, fuel recirculation type, non-electric	4	9	Starting systems:		
Heater, engine coolant and oil 240-volt external power	60	132	Air (TDI Turbine)	-22	-49
Hub odometer	5	11	Air (IR Turbine)	-14	-31
Oil Renewal System	11	25	Electric	358	789
Prelubrication system	24	53	Variable pitch fan, Flexxaire	273	600
Raycor fuel filters	14	30	Variable speed fan, Rockford	182	400
			Wheel chocks	44	97
			Wiggins service center	109	240

Truck Body

- The truck body is available in a variety of configurations and can be custom designed for the specific application. Your Caterpillar dealer can contact a CMT Truck Body application engineer for details.
- The Caterpillar Truck Body is part of an integrated design that includes the chassis and body interface. A non-Cat designed body could have negative effects on frame and power train life.

Weight / Payload Calculation

Example

	kg	lb
Empty Chassis Weight	114 420	252,252
Fuel Correction (90% x 1,200 gal.)	3478	7,668
Optional Attachments Weight	0	0
Debris Allowance (4% of chassis)	+ 4577	+ 10,090
Chassis Weight	122 475	270,010
Body Weight	24 948	55,000
Body Attachments Weight	+ 0	+ 0
Total Empty Operating Weight	147 423	325,010
Target Payload	+ 236 577	+ 520,990
Gross Machine Operating Weight	384 000	846,000

NOTE: Refer to Caterpillar's 10/10/20 Payload Policy for calculating maximum gross machine weight allowable for this target payload.

793C Mining Truck

AEHQ5186-03 (07-00)
Replaces AEHQ5186-01

www.CAT.com
© 2000 Caterpillar
Printed in U.S.A.

Featured machines may include additional equipment only for special applications.
See your authorized Caterpillar Dealer for available options.
Materials and specifications are subject to change without notice.

CATERPILLAR[®]